

Konstantin.ryka@tut.fi

Exam 30.01.2012

TLT-6306: RF Equipment for Wireless Networks
 Compiler: Jarno Niemela
 Calculators are allowed in this exam.

Answer to all questions!
 Total maximum points: 30 (+ exercise bonus)

1. Explain shortly:
 - a) Receiver sensitivity (2 p)
 - b) Space diversity (2 p)
 - c) Phase noise (2 p)
2. Explain the non-idealities (the phenomena) caused by typical analogue receiver front end components.
3. Using the values given in Figure 1, calculate the signal-to-noise ratio (SNR) at the receiver output (S2), when it is measured that the SNR at the LNA input (S1) is 13 dB. (6p)

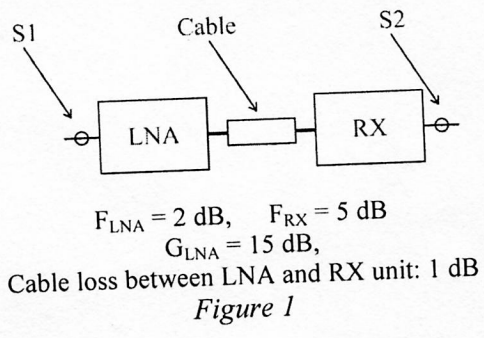

4. a) What additional RF-equipment you need and how to make the connections in Figure 2? Space diversity reception is implemented and only two feeders can be used. Antenna 2 is the diversity antenna. (3p)

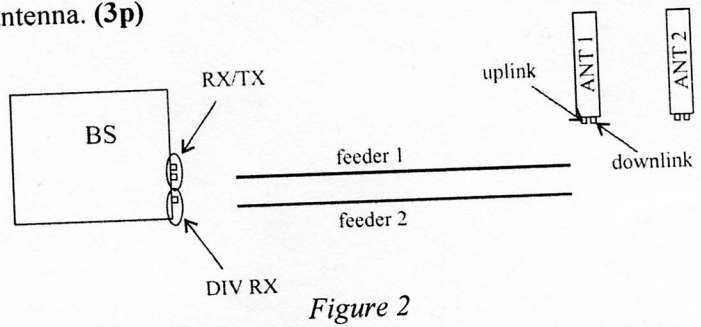

- b) How does the taper differ from splitter? Consider a 2-way taper. What is the power ratio in decibel scale between the output port #2 and the input port, if the power ratio between output port #1 and the input port is set to -7 dB. (3p)
5. On a Rayleigh fading channel, the received average signal energy is measured to be 17 dB above the noise level. Assume additive white Gaussian noise. The receiver in use is assumed to work satisfactory if the SNR is larger than 6 dB. How many branches are required for a diversity system exploiting selection combining to obtain a time availability of 99.5%?