

ELT – 41206 Basic Course on Wireless Communications, Exam 17 March 2016, Please give the answers in English. The attached 2-page formulas are allowed. Only basic calculators (scientific function calculators) are allowed. Exam's compiler: Elena Simona Lohan, TG315.

VERY IMPORTANT NOTE FOR STUDENTS: Please fit ALL your answers in maximum 4 single-sided pages (i.e., 2 double-sided pages); there will be 1 point loss for each extra single-sided page). Also, please answer in the given order (from 1 till 4), not in a random order. There will be 1 point loss if answers are not in increasing order.

1. (5 p) a) Assume that the transmitted power of an isotropic radiator is 5 kW and the operating frequency is $f = 2.5$ GHz.
 - a. What is the power density at the receiver 10 km away?
 - b. If the receiver antenna is isotropic, what is the total received power?
 - c. What is the transmission loss, assuming a free space loss model?
 - d. What is the transmission loss L_{dB} , assuming a simplified path loss model of the following type, with path loss coefficient $n=4$:

$$L_{dB} \approx 40.4 + 10n \log_{10} d_{km}$$
 - e. What happens with the transmission loss if the path loss coefficient n increases to 10?

(5 p) b) You are walking downtown Barcelona with your mobile navigator and you have just entered the Gothic district, having narrow streets and relatively tall building. Suddenly your GPS signal is lost. Enumerate 4 possible causes which might explain the loss of your navigation signal. Please avoid reasons such as 'my battery went off' or 'my phone has broken'. Also briefly explain how such causes could be alleviated or mitigated. Mention at least 4 methods which might be used to improve the navigation on your mobile device. Explain also briefly the main difference between navigation and communication signals.

2. (2p) a) Which is the spreading factor for the sequence illustrated in the figure below? If the symbol rate is 100 kbps, what is the minimum bandwidth needed to transmit the spreading sequence with the spreading factor of this figure?

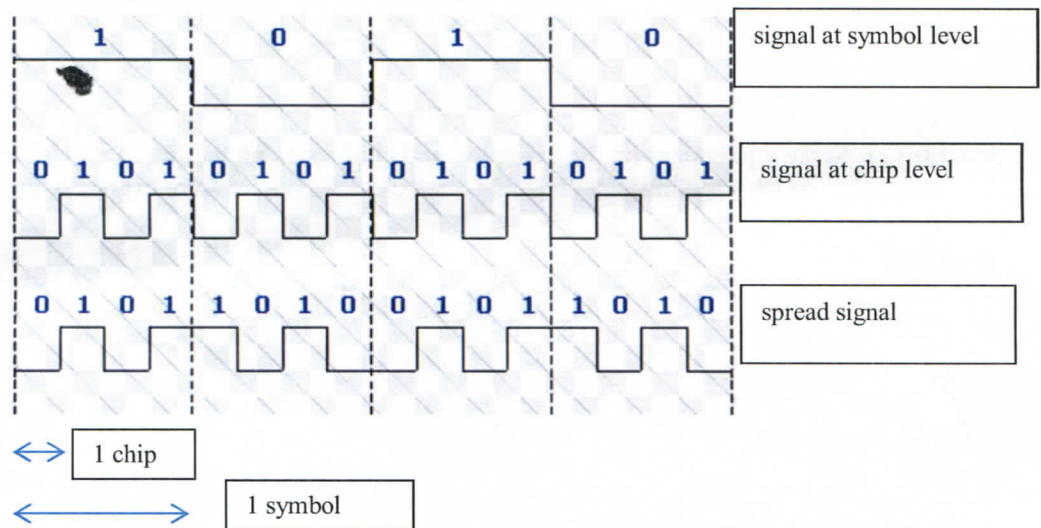

- (3p) b) Regarding WLAN architectures: i) What is an Independent Basic Service Set (IBSS) in the context of WLAN communications? ii) What is the Hidden Node Problem? Draw an illustrative example. iii) What are the main differences between IBSS and the Basic Service set (BSS)?

3. (2p) a) Draw a cluster of hexagonal cells, which has a re-use factor of 0.16667. Assuming that you can choose from a range of frequencies f_i , $i=1,2,\dots$, show what frequency is to be used in each cluster cell and in each cell of 2 neighbour clusters (with same cluster size)

(3p) b) Explain the near-far problem in CDMA systems. Give illustrative examples from both uplink and downlink situations. How you can alleviate the near-far problem in CDMA systems?

4. (4p) a) Compare UMTS with GSM according to the following table. If the results are not presented in a table of this form, they will not be considered

	GSM	UMTS
Modulation types(s)		
Multiple access types(s)		
Order of magnitude of maximum supported data rates		
Packet-switching support : Yes/No; add explanations if needed		

(3p) b) In the following plot, the autocorrelation of 2 CDMA code sequences is shown. Write which sequence has better auto-correlation properties and explain why. Draw an example of a good cross-correlation function between 2 pseudorandom sequences

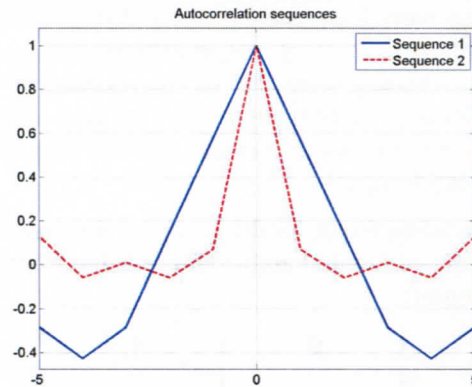

(3p) c) Make a judgment on the evolution and challenges on the future wireless communications (your ideas what on what will be next and what are the challenges we have to cope with)