

Question 1:

- A) Describe the term *characteristic harmonics* in connection with a six-pulse thyristor-controlled reactor (TCR). (2p)
- B) A static var compensator (SVC) connected to bus l through a connecting power transformer, injects reactive power Q to bus l of the power network, as shown schematically in Fig. 1. The nominal reactance of the TCR's linear inductor and the capacitor are 0.05 and 0.10 p.u., respectively. The leakage reactance of the power transformer is 0.10 p.u. Determine the amount of reactive power that the SVC would need to produce to keep the nodal voltage magnitude at bus l at 1.04 p.u. for the case when the thyristor's firing angle α_{TCR} is 120° . (4p)

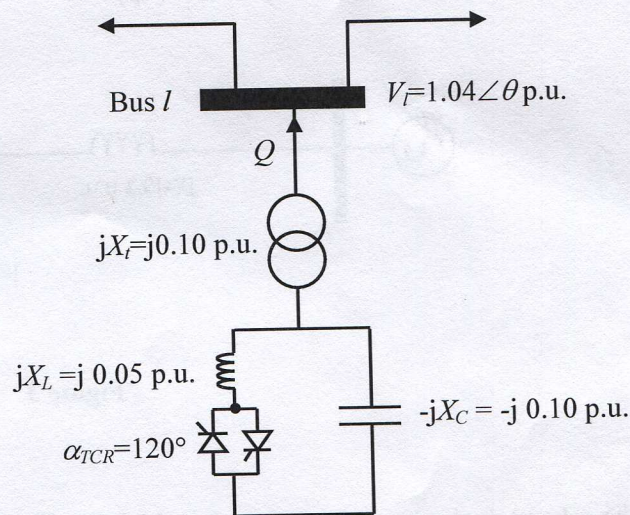

Figure 1

The TCR equivalent susceptance is:
$$B_{TCR} = \frac{2(\pi - \alpha) + \sin 2\alpha}{X_L \pi}$$

Question 2:

- A) State two practical power systems applications of a STATCOM. (2p)
- B) Explain the working principles of the bipolar, sinusoidal PWM control when operating in its linear region and in connection with a three-phase, two-level converter. In particular, refer to the amplitude modulation index and to the frequency modulation index, in your discussion. Use any equations and figures that you may find useful to enhance your explanation. (4p)

Question 3:

- A) Contrast the main constructional and operational differences of the so-called *static var compensator* and the *STATCOM*. (2p)
- B) For the circuit shown in Fig. 3 determine the nodal voltage solution at the end of the first iteration of the power flow Newton-Raphson method. Take bus 1 to be the slack bus. The voltage magnitude at bus 2 is kept at the specified value by action of the SVC connected at the bus. To start the iterative solution, assume the following starting values:

$$V_1 = 1 \text{ p.u.}; \theta_1 = 0 \text{ rad}; V_2 = 1 \text{ p.u.}; \theta_2 = 0.1 \text{ rad}; B_{SVC} = 0.5 \text{ p.u.}$$

The iterative power flow solution yields information of the voltage phase angle at bus 2 and the value of SVC susceptance. (4p)

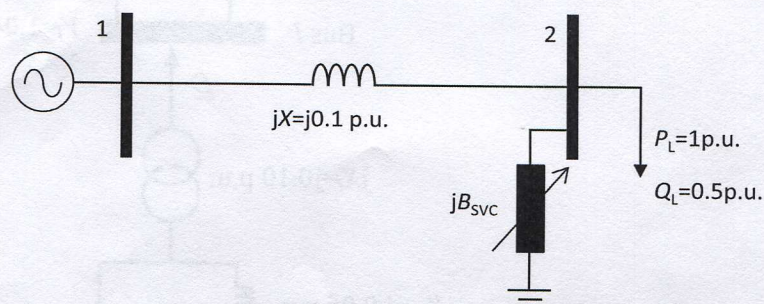

Figure 3

Question 4:

The schematic diagram of a conventional HVDC link is shown in Fig. 4. It uses two 6-pulse converters rated at 50 MW and 80 kV, to link a wind farm on an island to a load supply point in the mainland, some 70 km away. The island electrical subsystem is referred as System 1 and the mainland subsystem is referred as System 2. The line-line voltage at the high-voltage side of System 1's converter transformer is 192 kV and the frequency is 50 Hz. Its source inductance is 5 mH. The phase voltage at the high-voltage side of System 2's converter transformer is 270 kV and the frequency is 50 Hz. Its source inductance is 7 mH. The cable has a DC resistance of 3.75 Ω. If the HVDC link is carrying constant current of 400 A and delivering 30 MW into the inverter station, find the firing advance angle of the inverter and the firing angle of the rectifier. (6p)

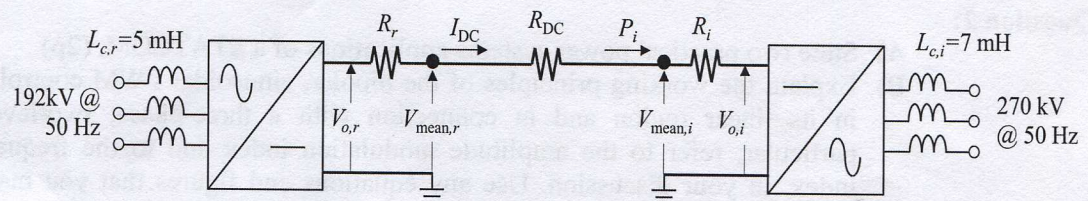

Figure 4

Question 5: Describe in detail the main physical and operational characteristics of a FACTS equipment of your choice, emphasizing those characteristics that can be accommodated within the Power Flow application using the Newton-Raphson algorithm. Use as many diagrams and equations as you may deemed necessary to carry out a comprehensive description. (6p)